

## Project A4: Ground/track/train systems interaction

Partners:



Researchers: Prof William Powrie, Dr Jeffrey Priest, Dr Chris Jones; Prof Chris Baker, Dr Michael Burrow

### Project aims:

To study and improve the understanding of the interactions between the ground, the track system and train vehicle behaviour, especially recursive processes giving positive feedback.

### Objectives:

- 1) To obtain field measurements that will help understand quantitatively and mechanistically the behaviour of different types of track systems subjected to different loads (whether through axle weight or train speed). Data obtained from two identical trains travelling at different speeds on a curved track show how sleeper displacement increases with train speed. How can the speed dependent response of the track be considered in track design?
- 2) To gather data on the geophysical properties of the ground and vibrations at the same sites. This will allow the ISVR 2.5-dimensional method for modelling ground vibrations from railways to be more accurately assessed. Accurately validated models can then be used in substructure and soil engineering design studies to reduce vibration from railways. Images show vibrations emanating from a moving train along a track.
- 3) To develop analytical and numerical models for track systems that enable the interdependence of the vehicle dynamic response, groundborne vibrations and the geotechnical characteristics of the track system to be included. The images below Flexible Track System Model (FTSM), with interaction forces between a railway wheelset and ballasted track (DTI/EPSC Technology Programme with Partners: Manchester Metropolitan University, Corus, Network Rail, MSC Software and Carillion); and output from dynamic FEA model showing impact or rail irregularity

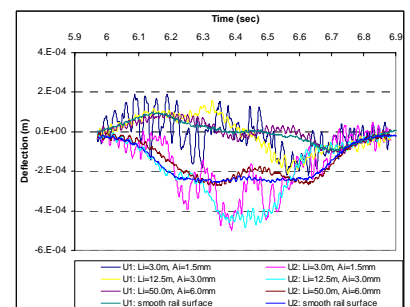
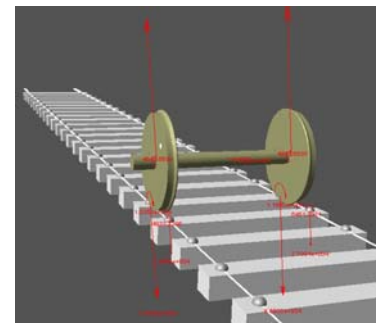
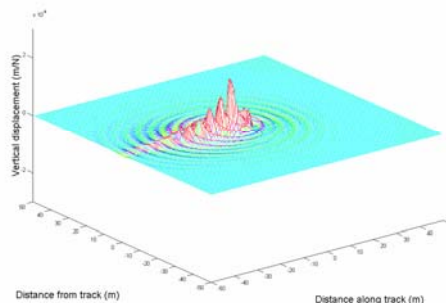
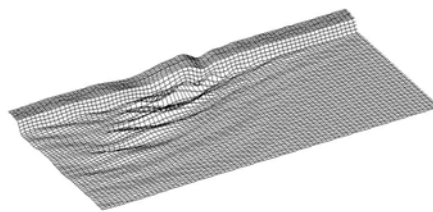
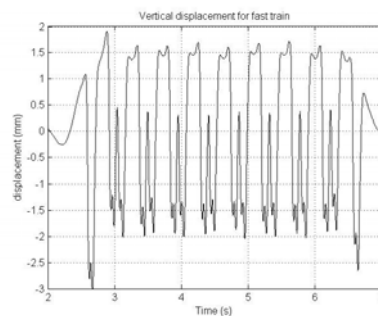
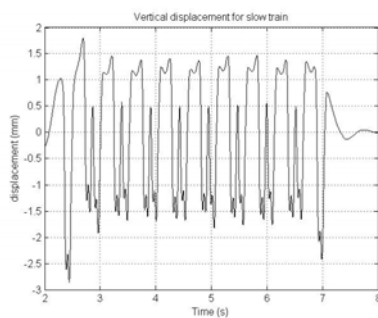

### Contact:

Dr Jeffrey Priest  
School of Civil Engineering & the Environment, University of Southampton, Highfield, Southampton SO17 1BJ  
E-mail: [J.A.Priest@soton.ac.uk](mailto:J.A.Priest@soton.ac.uk), Tel: +44 (0)2380 598454, Fax: +44 (0)2380 677519